



Continuous Harvesters and onsemi's Low-Power RF Technology Close the Gap in Environmental and Accelerometer Sensors for IoT



ON Semiconductor®

Continuous Harvesters and onsemi's Low-Power RF Technology Close the Gap in Environmental and Accelerometer Sensors for IoT

BACKGROUND

While the proliferation of the Internet of Things (IoT) is inarguable, only few publications have so far enlightened the public regarding the problem of energy availability to support the rapidly-growing number of sensors and transceivers.

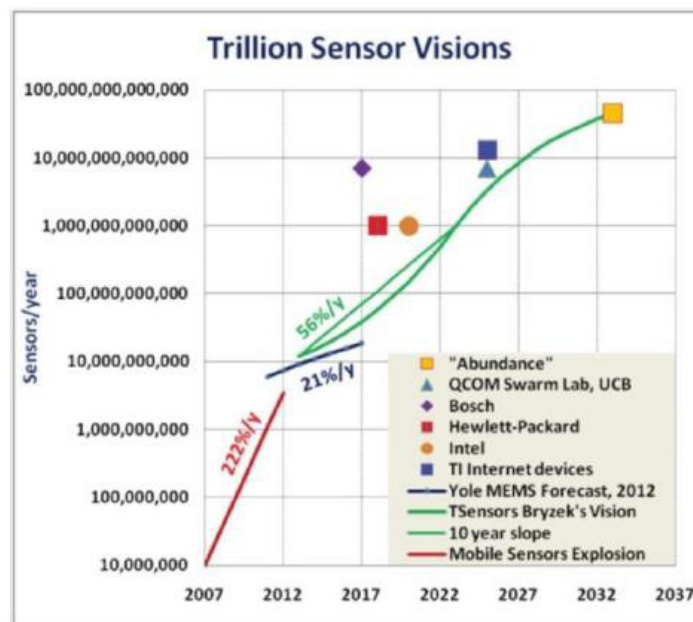

Figure 1. Forecast of Number of Sensors Deployed Annually (Source: Sia and Tsensor.org 2015)

At the 2018 World Material Forum in Nancy, France, it was confirmed that the rapid growth of IoT combined with the high requirement of data storage, processing and transmission will become a big concern for the sustainability of the project. As such, any type of energy harvesting solution is welcome, if not absolutely mandatory.

Comprehensive potential solutions to this challenge include:

- Designing ultra–low–power embedded hardware platforms
- Intelligent system–level power management
- Making devices self–powered by harvesting energy from their operating environment

When implementing these solutions, the electronic designer has to keep in mind that an IoT sensor device will not only have to measure a value (including temperature, moisture, pollution, light level), but also be able to communicate the value to its system host– often wirelessly– with a limited power supply.

To make this a reality, every single system–level component of the design must be considered thoroughly, including the sensor, receiver, energy source, and the communication duty–cycle.

This white paper will examine how **onsemi**'s energy efficient solutions can be used to enable battery–less applications with cutting–edge, continuous sensor technology.

ULTRA–LOW–POWER TRANSCEIVERS AND COMMUNICATION PROTOCOLS

The first step of the design is to select an RF transceiver that is both ultra–low–power and supports a wireless protocol for transmitting information.

An adequate wireless protocol should support and include the following features:

- Support Local Area Network transmission distances (approximately a few 10 s of meters indoor)
- Be low power by construction (short frames and low Tx power allows to reduce CPU and radio power budget)
- Enable secure transmissions (E.g, Encryption)
- Offer a simple receiving mechanism (Beacon)
- Offer user–friendly hardware implementation (E.g, a direct interface between the sensor and transceiver)
- High integration level (SiP or single chip)
- Offer standardized communication protocols (IEEE or SIG style), including interoperability between the sensor node and Gateway
- Low implementation cost to support mass–market availability

Fortunately, the Bluetooth® SIG organization and Zigbee® Alliance now offer wireless protocols focused on optimizing their respective protocols for several years. Now, we have Bluetooth 5 as well as Zigbee Green Power protocols available with optimizations made on short frame duration, security and transmit power.

It is possible to transmit all what is required for a connection within less than 10 milliseconds (ms).

The key point is how to implement those protocols in an energy optimized component and make best use of voltage and current resources.

onsemi has designed devices based upon its expertise in ultra-low-power microcontrollers and audio for hearing aids, resulting in power budgets as low as 10 mW at 6 dBm. Several products are now available to overcome the challenge: NCS36510 supporting Zigbee protocol and RSL10 for Bluetooth Low Energy.

Combination of protocols and smart power implementation requirement leads to the equation shown below in Figure 2.



Figure 2. 'Rule of Thumb' for IoT Application Energy Consumption

SELECTING AN ENERGY HARVESTING SOURCE

The equation in Figure 2 gives us a guiding principle for the energy requirements of a modern low-power connectivity and communication protocols. What remains is to select the appropriate harvesting source and domain of use. Time is another element that must be factored in.

The power generated by a continuous harvester may be low but the purpose is to accumulate it over time so that a gain factor is significant. For example, harvesting for 1 second and transmitting for 10 ms creates a gain of 100. In comparison, harvesting for 10 seconds and transmitting for 5 ms creates a gain of 2000.

Energy accumulation in the range of few seconds is fully supported by technology of electrolytic capacitors.

SOLAR-BASED ENERGY HARVESTING

Using the RSL10 Bluetooth 5 radio or the NCS36510 Zigbee System-on-Chips (SoC) as examples, we can calculate that we will need approximately 10 mA of current during a protocol transmission lasting to a maximum of 10 ms. For a transmission every second, we can factor a gain of 100x. If the transmission occurs every 10 seconds, the gain will be 1000x. This means that we can target a current source of $10 \text{ mA}/100 = 100 \mu\text{A}$ or $10 \text{ mA}/1000 = 10 \mu\text{A}$ for the solar harvester.

Interesting enough, a solar cell like FlexRB-25-7030 from Ribes Tech provides $16 \mu\text{A}$ at 200 lux or $80 \mu\text{A}$ at 1000 Lux. This is exactly what's needed.

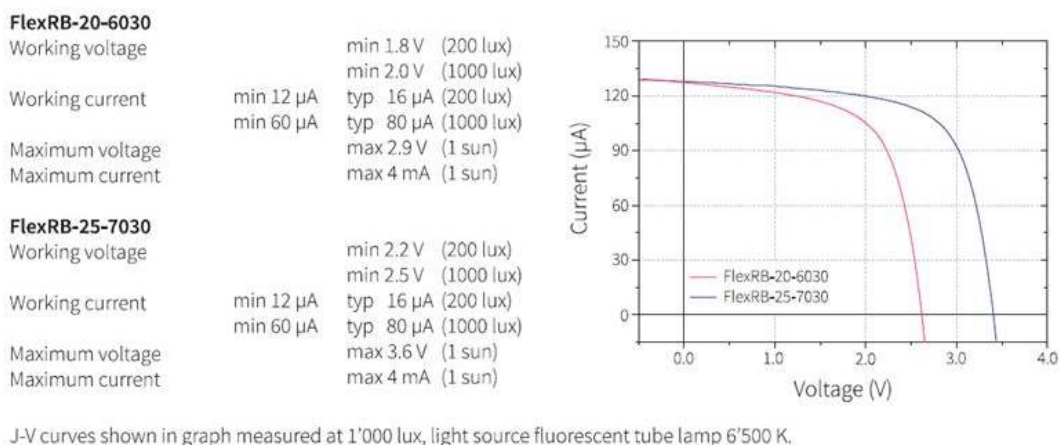

Figure 3. Electrical Specifications of the FlexRB-20-6030, FlexRB-25-7030 from Ribes Tech

Using a solar cell like FlexRB-25-7030 from Ribes Tech will allow us to supply an autonomous sensor that is transmitting a Bluetooth Low Energy or Zigbee frame at a duty cycle comprised between 1 and 10 seconds.

COMMON LIGHTING CONDITIONS

Most solar cells are characterized over two sets of lighting conditions: 200 lux and 1000 lux. Those conditions cover a wide range of day-to-day illumination, as shown in the table below

Table 1. COMMON LIGHTING OPERATING CONDITIONS

Weather Conditions	Light Source	Time	Solar Cell Facing	Sensor Location	Lux Level*
Cloudy Winter	Natural	11:00 am	Sky	Office, Near Window	415
“	“	“	Indoor	Office, Near Window	230
“	“	“	Outdoor	Office, Near Window	630
“	“	3:40 pm	Indoor	Office desk	200
“	Ceiling Neon	11:00 am	Ceiling	Office Corridor	340
“	“	“	White wall	Office Corridor	220
“	“	“	Ground	Office Corridor	140**
“	“	4:30 pm	Ceiling	Office desk	250
“	Natural	9:00 am	Window	Automotive Dashboard	700
“	“	“	Ground	“	350
“	“	“	Front seat	“	400

*Measurements made with the Luxmeter app from Velux running on iPhone® 6.

**Not recommended as operating conditions with actual configuration.

CONTINUOUS MEASUREMENT DOMAINS

Based on the information previously mentioned in this document, we can start examining the behaviour of the entire harvesting system.

There must be an energy pre-load phase so that the device is harvesting energy from the solar cell prior to triggering the first communication. The next section (Technical Challenges) will detail the various tips and guidelines for successful implementation. Once the device has captured and stored enough energy, the microcontroller (MCU) has to set up communication parameters, Tx power, channel selection, and temperature measurements.

This activity will be obtained while the MCU is mostly active, so the buffered energy must be high enough to transmit as many beacon frames as possible.

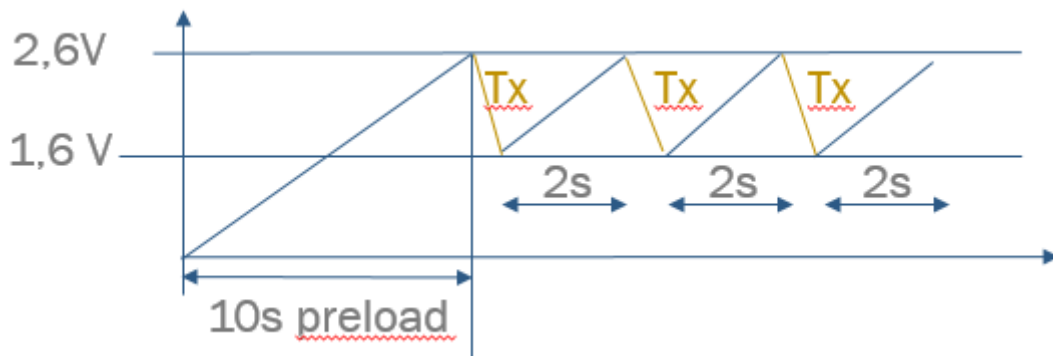

Figure 4. Conceptual Energy Consumption View at a Given Lighting Condition

With 2 seconds of duty cycling, we can implement a battery-free sensor node capable of measuring slow-changing parameters (E.g, moisture, temperature, atmospheric pressure, indoor parameters, light intensity).

TECHNICAL CHALLENGES AND IMPLEMENTATION

Connectivity

The initial step is the choice of the communication and data processing IC that is able to support the desired communication protocols with the available energy budget dictated by the harvesting device. In most cases, it is required that the selected devices support effective Standby and Deep Sleep Modes to preserve energy when no operations are required. To simplify the power delivery, devices with low minimum input voltages or wide input voltage ranges are preferred. In this way, a simple step down or linear regulator can be used to regulate or limit the system voltage.

Similar requirements apply to the sensors used in the system. In case no Sleep Modes are available, power gating could be implemented to disable the power-supply for the sensors when no sensing is required.

Energy Storage

The next section to consider is the energy storage and energy management that is used to supply of the sensors and the microcontroller.

For storing the harvested energy, multiple approaches are possible. Which approach is best suited depends on the requirements of the target application. Typically capacitor or battery based solutions can be used.

Capacitor based solutions typically have a lower overall capacity at the same volume due to their lower energy density compared to batteries. This makes batteries more suitable for sensors that require in order to remain operational for an extended period without light exposure.

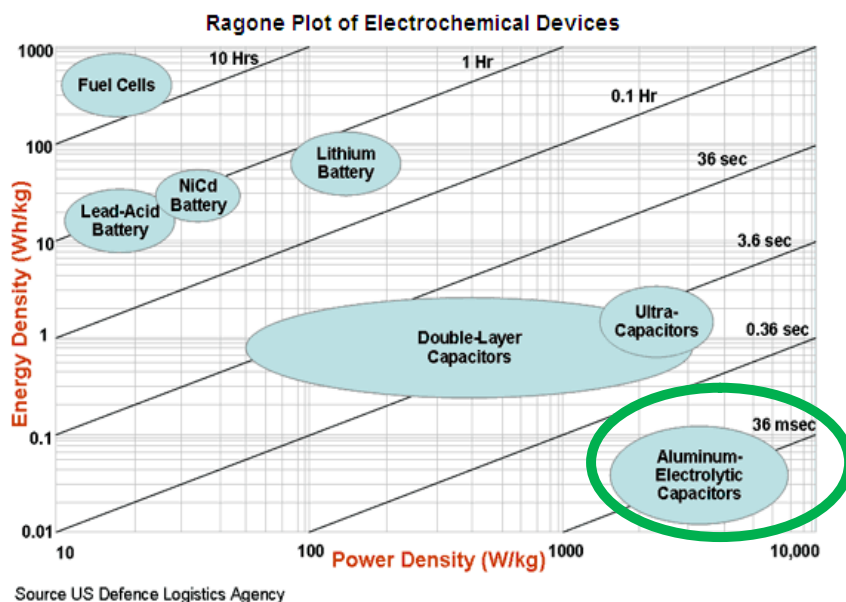

Figure 5. Ragone Plot Helping us to Select the Adequate Storage Technology

The challenge with battery-based systems is that they typically require a more complex energy management. This includes charge and discharge control as well as cell protection against over charge and over discharge. This increases the system complexity as well as the BOM (cost) as such energy management systems often involve switching regulators (additional passive components) and result in a more complex ICs due to the functionalities required. The chip complexity in addition to the requirements of high efficiency and low quiescent currents often leads to rather expensive IC solutions.

In applications that do not require extended operation periods without being exposed to light a capacitor based solution can be a more (cost) effective solution. The storage capacitor temporarily accumulates the energy from the solar harvesting device until sufficient energy is available to perform a measurement and transmit the result. When a capacitor with adequate voltage rating is used, no charging circuit is required. The open circuit voltage of the used solar harvester when exposed to the expected peak brightness determines the maximal input voltage. If the capacitor has a voltage rating that exceeds the open circuit voltage, no charging circuit or protection is required.

For both, battery and capacitor based solutions an output voltage regulation is required to supply the attached circuits (sensors, microcontrollers, etc.) with the correct voltages. Systems that use a lithium based storage options reach voltages above 4 V, which often exceeds the input voltage range of sensors and microcontrollers. To match the supply voltage of typically 1.8–3.3 V, a step down voltage conversion is required. In capacitor based systems the voltage is linearly dependent on the amount of charge stored. This can lead to great voltage variations over the discharge cycle, which cannot be accepted by all sensors or microcontrollers and hence requires some kind of regulator to stabilize the supply.

RSL10 SOLAR CELL MULTI-SENSOR BOARD

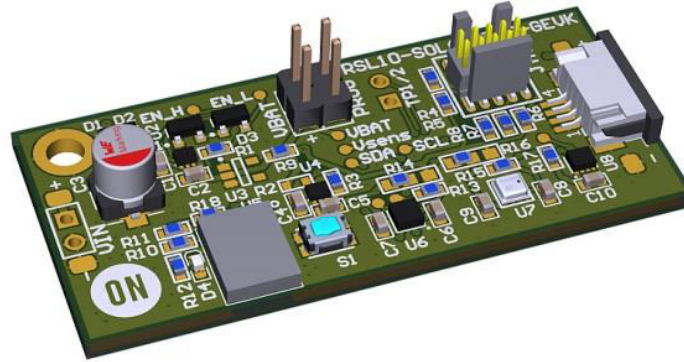

Figure 6. RSL10 Solar Cell Multi-Sensor Board

The RSL10 Solar Cell Multi-Sensor Board (RSL10-SOLARSENS-GEVK) is a comprehensive development platform for battery-free IoT applications including smart building, smart home, and Industry 4.0. Based on the industry’s lowest power Bluetooth Low Energy radio (RSL10), the board features multiple sensors for temperature and moisture-sensing (BMA400—a smart 3-axis accelerometer, BME280— a smart environmental sensor, and NCT203 wide- range digital temperature sensor).

The board also features an ultra-low cost, low weight, and low profile storage capacitor of 47 μ F, a programming and debug interface, and a connected solar cell.

Since the device is harvesting energy from a low current source, it is important that the leakage of the overall system is small while operating and harvesting energy. Several smart devices are selected for that end, including an ultra-low quiescent current LDO (NCP170), which is populated on board.

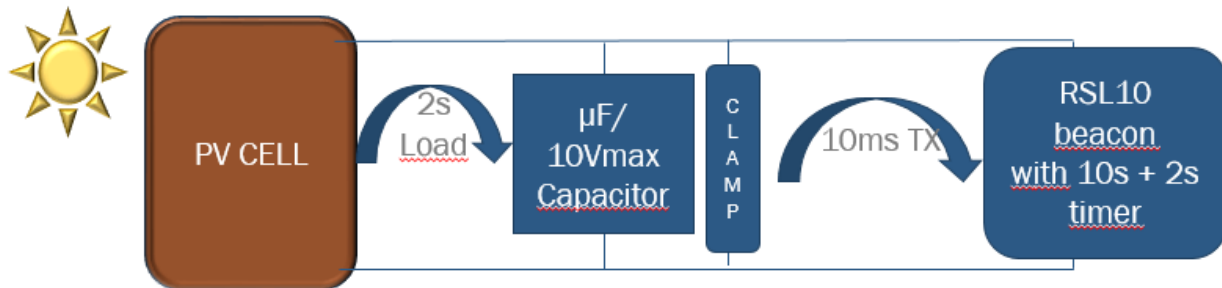

Figure 7. Conceptual View of the Multi-Sensor Board



Figure 8. Complete System Outlook Including Sensor, Gateway and Cloud Service

With this list of assets the potential applications are vast, let's have a quick glance at them:

Smart Building:

- Climate control (Env)
- Windows breaking detection (3 Axis Accelerometer)
- Building Automation (both)
- Door breaking detection (3 Axis Accelerometer)
- Windows / Door open / close status report (3 Axis Accelerometer)
- Meeting room occupancy monitoring (both)

Smart Home

- Ambiance control (Env)
- Roof and windows control (both)
- Windows breaking (intrusion) detection (3 Axis Accelerometer)

Industry 4.0 / Smart City

- Air Pollution detection (Env)
- Workers Safety (both)
- Security and surveillance (3 Axis Accelerometer)

Mobile Health

- Integrated / portable sensor (3 Axis Accelerometer)
- Bike / Motor bike Active helmet (3 Axis Accelerometer)



Figure 9. Battery-free Windows Sensor Demonstration at Embedded World 2019

Hardware Set-up and Optimization

The RSL10 Solar Cell Multi-Sensor Board uses **onsemi**'s RSL10 to process the measurement data and transmit the results as Bluetooth Low Energy advertising packets. The packets can be received using smartphones or any other Bluetooth Low Energy capable device for visualization.

An aluminum electrolytic capacitor will be used as the main energy storage. The solar harvesters used have open-circuit voltages in the range of 3–6 V, so a ~10 V rated capacitor can be used in the circuit without any input clamping or protection. In the circuit, the capacitor is directly charged by the solar harvesting element with only a Schottky diode in series. The diode is placed to avoid the harvester from discharging the capacitor. The capacity of the capacitor is discussed later as it depends on several additional aspects that are discussed in later sections.

The RSL10 SoC contains an integrated DC/DC buck regulator that allows the chip to operate over a wide range of input voltages (1.1–3.3 V) without additional regulators. As the used solar harvesters might exceed the maximum voltage ratings of the RSL10 in very bright situations, a linear regulator is used as a voltage limiter. In case the input voltage exceeds 3.3 V, the regulator generates a constant supply voltage; if the voltage is below 3.3 V, the regulator passes the capacitor voltage without regulation. As the regulator is only in use in circumstances where “too much” energy is available, it is non-problematic that the excess energy is converted to heat. If the demand for power increases, the capacitor voltage will drop and the regulator will be no longer active and “waste” energy. The simplicity of the regulator, however, leads to lower quiescent currents. This is essential, as it will help to preserve the available energy in low-light situations. Figure 10 shows a typical operation scenario, where the voltage is limited in periods with lower power consumption. When the capacitor voltage drops below 3.3 V (due to higher power draw) the LDO regulator is no longer active and passes the voltage directly.

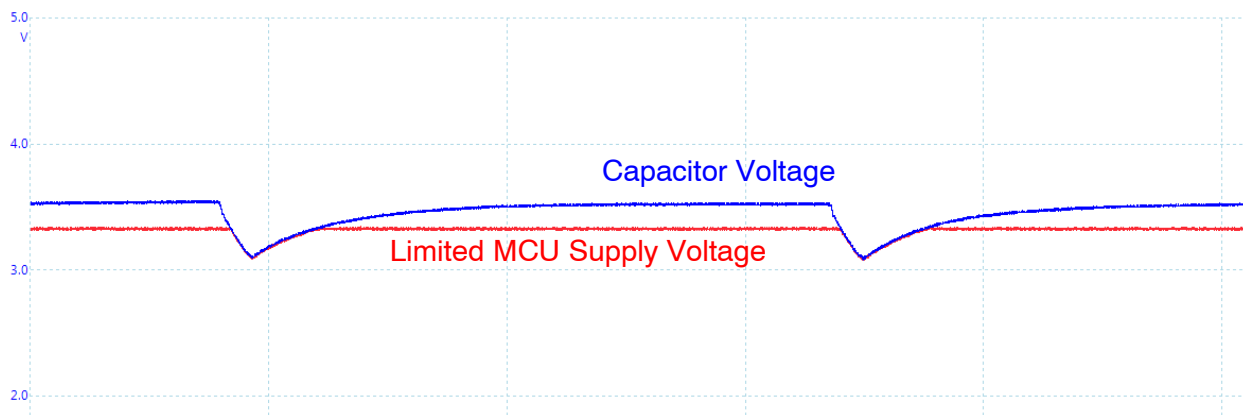

Figure 10. Voltage Limiting Using an LDO Regulator

When the system is fully discharged and then exposed to light, the capacitor voltage will slowly rise as charge is accumulated. By default, the RSL10 will (try to) start up once it reached its lower threshold voltage of ~ 1 V. This can only work if the solar harvester is continuously delivers the power needed for the start-up to maintain the capacitor voltage at 1 V. If the solar harvester delivers less power than required, the capacitor voltage will drop. When the voltage is below the threshold of ~ 1 V, the start-up fails as the RLS10 will turn off. This sequence will repeat while the energy output of the solar harvester is lower than the RSL10 consumption during start-up. As the harvester is typically not able to generate that much energy in all (lighting) situations, a start-up circuit is required to ensure reliable start-up.

The circuit used for this demonstrator makes sure that the storage capacitor is sufficiently pre-charged before the RSL10 and other devices are powered. Guarantee a successful start-up, the storage capacitor needs to hold the energy as is required for the full start-up of the system. In our case, the start-up is the sequence from initial power-up until the point where the system can enter its deep sleep mode.

The energy required to execute this sequence can be measured. Based on the required energy and the typical input voltage range for the microcontroller, the required minimum capacitor size is determined. For the presented RSL10-based implementation, ~ 120 μJ are required for the start-up. In combination with a desired voltage range from ~ 1.5 – 3 V, this leads to a theoretical minimum capacitance of 35.6 μF . In practice, a bigger capacitor should be used to compensate capacitance variations caused by factors like manufacturing tolerances, different operating temperatures or component aging.

Start-up and Maintain Circuitry

To enable and disable the power to the RSL10, the enable signal of the clamping LDO regulator is used. The input for the enable is generated by two sources. The first source is generated by a voltage supervisor IC (**onsemi's** MAX809) that is supplied by the capacitor input voltage and will enable the LDO regulator once the capacitor voltage has exceeded 2.63 V. The second input is used to ensure that the enable pin remains high as long as the output voltage is sufficiently high. Depending on the required threshold, the default turn-off threshold of the LDO can be used (for NCP170 >1.2 V; measured at ~1.5 V). In this case, the output voltage of the LDO is fed back to the enable pin. In case a higher turn-off voltage is desired, an additional voltage supervisor with a threshold of >1.5 V can be added that will pull down the enable once the LDO output drops below the threshold defined by the voltage supervisor. Figure 11 shows the schematic of the start-up circuitry used. U3 is the secondary voltage supervisor that is optional depending on the desired threshold voltage for the turn-off.

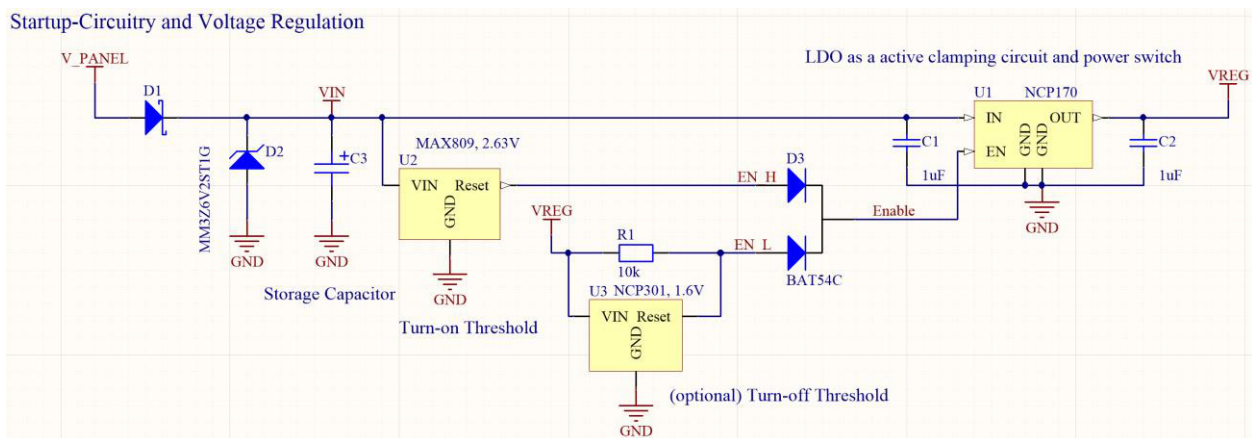

Figure 11. Start-up Circuit Schematic

In Figure 12, the behavior of the start-up circuitry can be observed. Before Point A, the capacitor voltage rises slowly until it reaches 2.63 V in Point A. The voltage supervisor has an internal delay that delays the actual turn on by t_D which is between 140–460 ms for the used part. After the delay, the MCU supply is activated. While the MCU supply voltage is above ~1.5 V the system can operate normally. Once the voltage drops below 1.5 V (Point B) the MCU supply voltage is disabled as the enable pin threshold is 1.5 V for the used NCP170. Afterwards, the capacitor voltage needs to rise above 2.63 V again to re-enable the MCU supply.

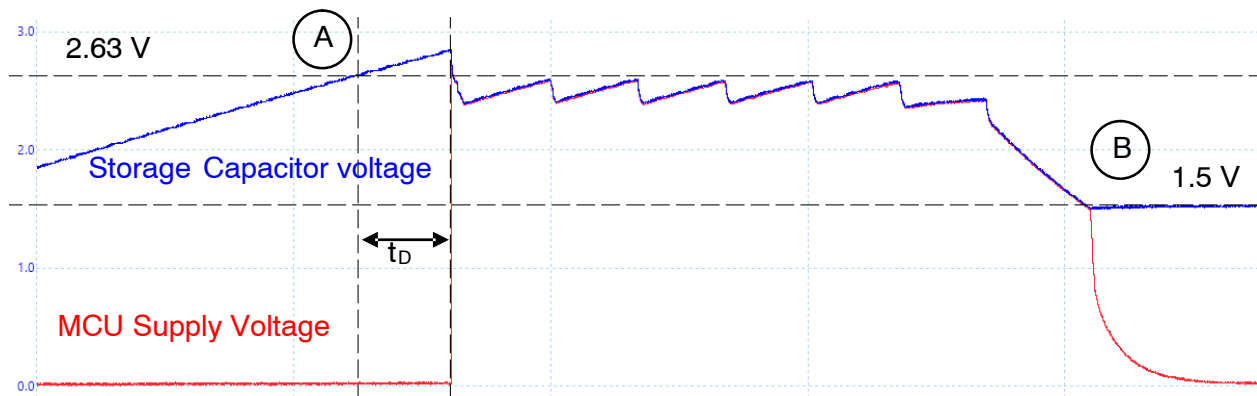

Figure 12. Start-up Circuit Behavior

The board contains sensors for temperature, air quality, and acceleration. All sensors support Sleep Modes to reduce the energy consumption when not required. To avoid the varying capacitor voltage from having a negative influence on the data acquisition, a regulated sensor supply voltage of 1.8 V is used. This sensor supply voltage can be disabled to even further reduce the current consumption. The sensors interface with the RSL10 SoC via an I²C bus.

The temperature sensor and the accelerometer support operating modes where the sensors can monitor the respective physical conditions without the interaction of the RSL10. In this mode the sensors use dedicated interrupt lines to wake up the RSL10 in case the monitored value is outside a preconfigured range or an otherwise programmed condition has occurred.

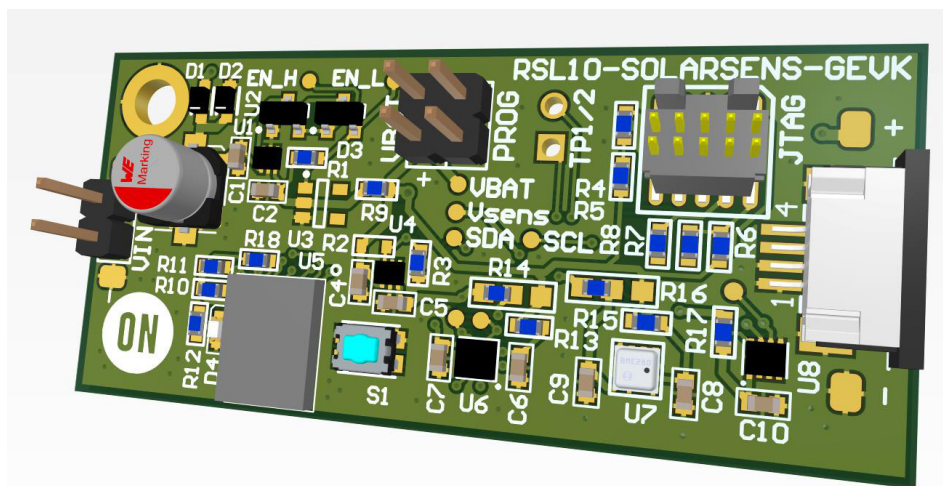

Figure 13. RSL10 Solar Cell Multi-Sensor Board

The resulting PCB is 24 x 51 mm in size using a 2-layer design with all components on the top side to be able to connect the solar harvesting device on the backside.

The solar harvester can be connected in the following ways:

- Using a 100 mil spaced connector on the left side of the board
- A 4-pin 1 mm spaced ZIF connector on the right side of the board
- Solder pads on either side of the board to directly attach a panel or additional connector

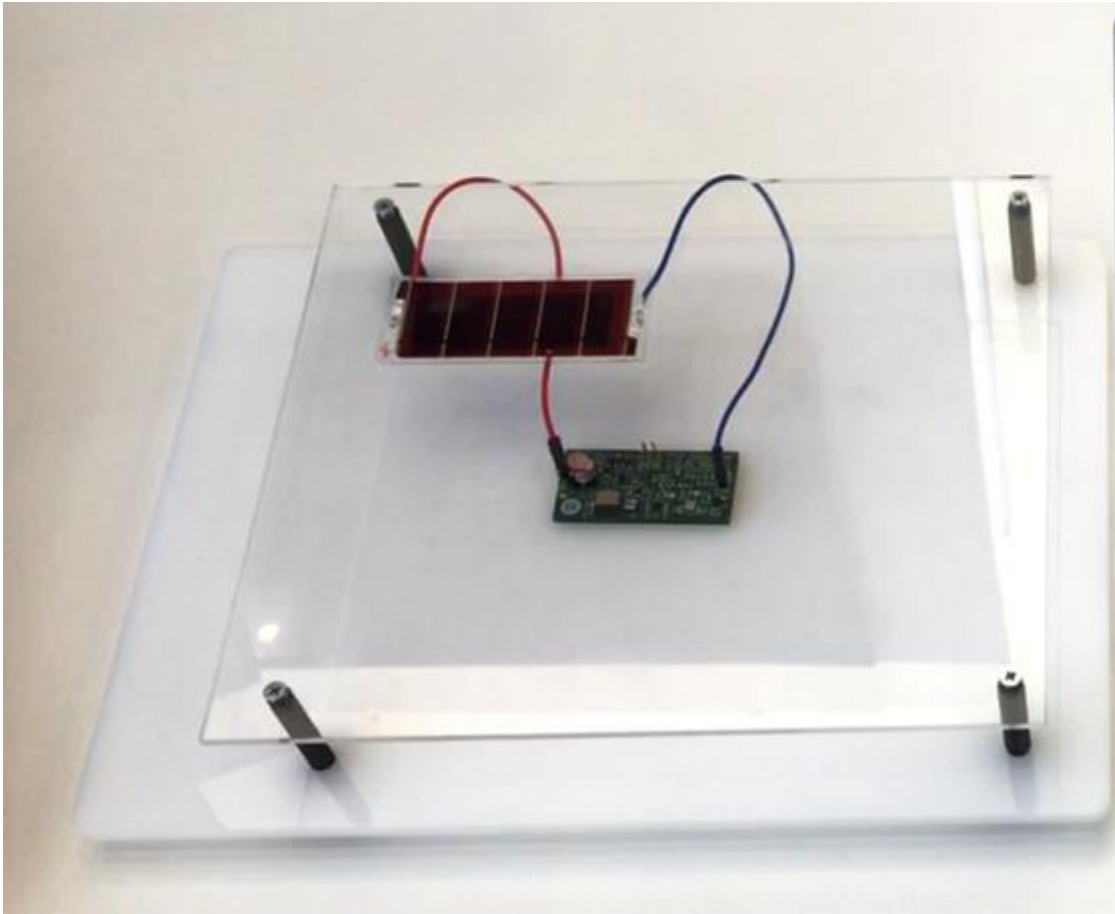

Figure 14. Battery Free Multi-sensor Node as Demonstrated at EWC 2019

FIRMWARE SET UP AND OPTIMIZATION

The target behavior of the RSL10 Solar Cell Board is to measure environmental parameters and transmit them as Bluetooth Low Energy advertising packets. The intervals in which the measurements and transmissions are happening is dependent on the available energy. The firmware needs to monitor the available energy and adjust the system power states in order to optimize the performance of the system.

When the system is starting up, the RSL10 initializes all required peripherals, clocking resources and the Bluetooth Low Energy base-band. These steps are essential to have all power states of the RSL10 available. To save power, all un-used peripherals remain disabled. In addition, the power supply for the sensors is deactivated until an actual measurement needs to be done.

After the RSL10 is initialized, the system needs to decide if it has sufficient remaining energy to perform some measurements or if it is necessary to enter the ultra-low-power Deep Sleep Mode to let the storage capacitor charge up to a higher voltage level. To determine the currently available amount of energy, the RSL10 can measure the supply voltage. A voltage of 3.3 V indicated that the capacitor is full and the LDO is already limiting the output voltage. For supply voltages below 3.3 V, the RSL10 is directly measuring the capacitor voltage and can determine the energy contents.

If the amount of energy is insufficient to perform the required measurements, the RSL10 enters its Deep Sleep Mode. In this mode, the power consumed by the RSL10 is in the range of 62.5 nW, which allows the storage capacitor to recharge, even in situations with low light. In deep sleep mode the RSL10's peripherals are disabled. To preserve the state of some system variables during the deep sleep mode a section of the RAM is retained. The wakeup from Deep Sleep is a significantly faster and requires far less energy than a full start-up.

After a fixed period of time in Deep Sleep Mode, the RSL10 wakes up to check if the storage capacitor has accumulated sufficient energy to perform the measurements and transmit the data. The energy-thresholds that determine if a measurement is possible was determined experimentally. In case the energy level is still insufficient, the RSL10 again enters the deep sleep mode.

If the available energy is sufficient for a measurement, the power supply for the sensors is enabled and the I²C interface is initialized. Via I²C, the sensors are configured to perform their measurements. Once the measurements are completed, the results are read back and copied into the advertising packet that is used to transmit the measured data.

The advertising packet containing the measurements is transmitted afterwards. After the transmission, the RSL10 enters the Deep Sleep Mode for the time of the minimal desired transmission interval. Afterwards, the sequence repeats, starting with determining the amount of available energy after the wake up.

Bluetooth Low Energy Considerations:

The use of advertisement packets for transmission of measured sensor data to other devices was chosen as the most power efficient way to transmit data over Bluetooth Low Energy. This gives the RSL10 Solar Cell Board's harvester means to target all scanning Bluetooth Low Energy devices in its close vicinity without the need to establish and maintain a connection. Additionally, the solar harvester transmits data in Broadcaster Mode, meaning it does not enable receiver after each transmitted advertisement packet. This saves additional power at the cost of not being connectable and being unable to send scan response packets which raise the maximum limit of advertisement data from 31 bytes up to 62 bytes. Depending on application needs, it might be desirable to advertise in connectable mode to allow some devices to configure parameters of the sensor node like preferred advertising interval and preferred measurement interval.

To overcome the limitation of small advertisement packets that allow only 31 bytes of data it is possible to switch between different advertisement payloads at each advertisement interval. This can be used to send custom sensor data frame in one advertising packet followed by Eddystone Beacon URL frame in next advertising packet. The Eddystone URL packet can be used to link to web page with additional information and offer to download application for displaying of sensor data.

Unlike for connected devices where Environmental Sensing Service is defined by Bluetooth SIG, there are no standardized formats for transmitting a wide variety of sensor data using only advertisement packets.

As such, a custom advertisement data frame is used to pass sensor data to scanning devices. These devices need to have specialized software or application that is able to parse and process the content of such advertisement packets. This might not pose an issue in industrial use-cases where the entire infrastructure is managed by single entity but may cause interoperability issues if applied to markets where devices from multiple vendors may need to collaborate.

Firmware Implementation

Based on behavior described above, a firmware was developed for the RSL10 Solar Cell Multi-Sensor Board.

An Eclipse-based environment RSL10 SDK is provided by **onsemi** for software development on RSL10-based platforms. The RSL10 SDK contains fully integrated development environment with a powerful editor, toolchain, documentation, a wide range of example code, and a CMSIS-Pack based software packages.

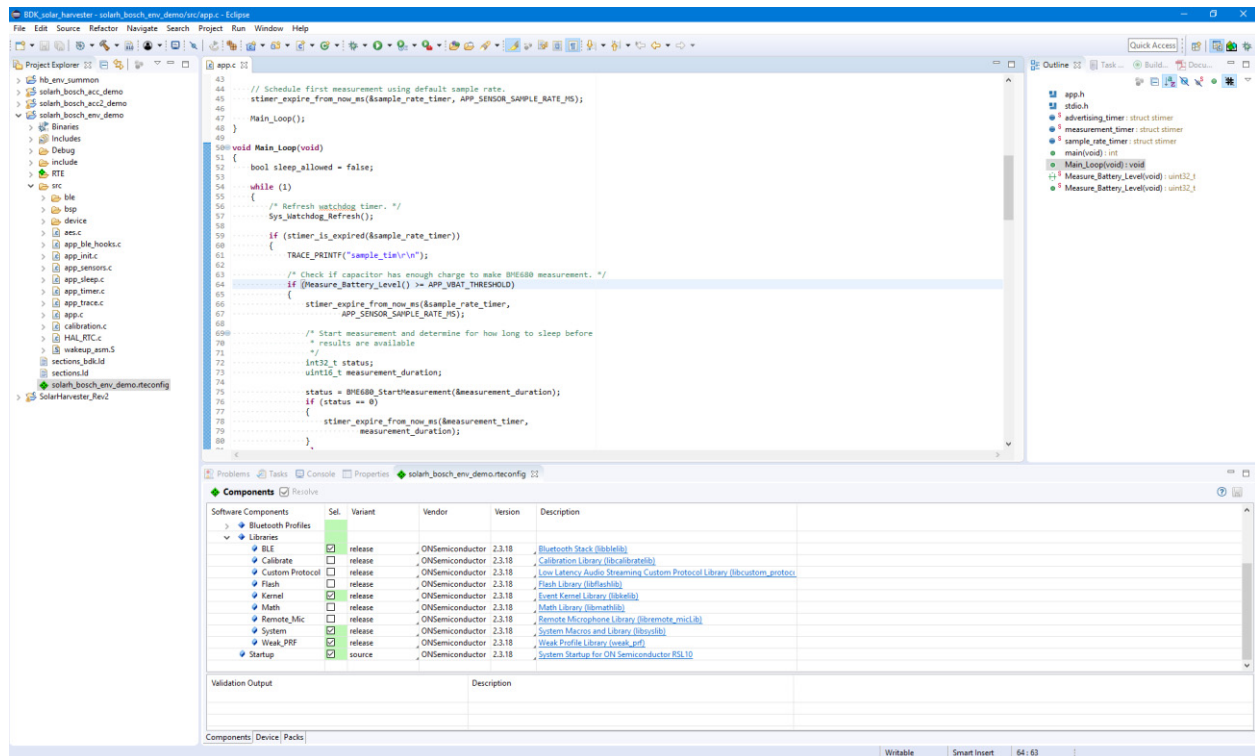

Figure 15. RSL10 Software Development Kit (SDK)

The firmware can be configured using the CMSIS Configuration Wizard editor included with the RSL10 SDK as shown in Figure 16. This allows to quickly evaluate different software configurations by changing desired parameters using graphical interface that provides detailed description and checks for correct range of entered values for each parameter. For cases when more complex changes are required for evaluation, source code and sample projects are provided in the in the CMSIS–Pack.

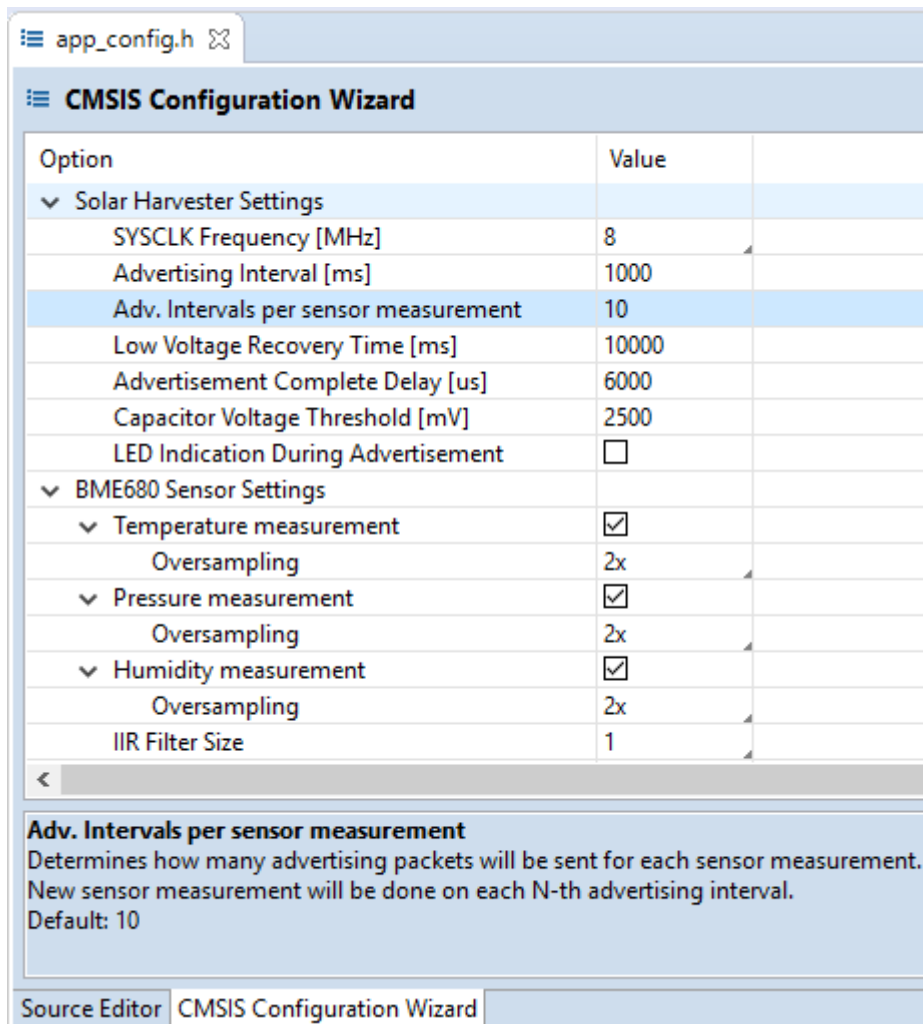

Figure 16. Configurable Parameters Shown in the CMSIS Configuration Wizard

Figure 17 shows the current consumption of the board during a sensor measurement event, followed by advertisement of measured data. During this event, a total of 60 μJ of energy was used to both measure sensor data and advertise the results. If sensor measurement is not scheduled and the board only advertises, the energy consumption is reduced to 20 μJ .

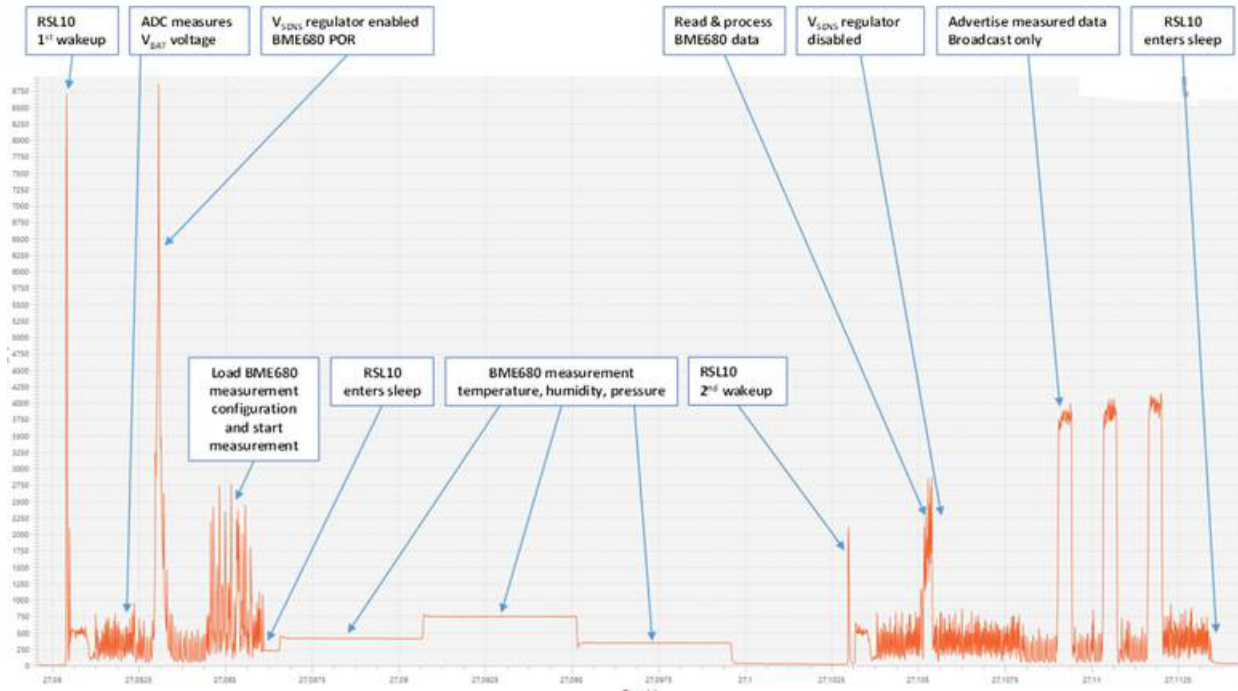

Figure 17. Typical Operation Cycle with Sensor Measurement and Advertising (3 V Power Supply, Advertising Interval set to 1 s, and Sensor Measurement during Every Advertising Interval)

Receiving Beacon Data

Sensor data advertised by the RSL10 Solar Cell Multi-Sensor Board are included as part of manufacturer specific data section of advertising packet along with Bluetooth Low Energy flags and complete local name of the board. This allows to get access to sensor data to all devices which expose manufacturer specific data to applications, including Android™ and IOS® devices.

In this scenario, the RSL10 USB dongle (RSL10-USB-001-GEVK) is connected to a host PC was used to display captured sensor data. The RSL10 USB dongle and accompanying software Bluetooth Low Energy Explorer with Python bindings were used to create simple script that scans for nearby Bluetooth Low Energy devices, and displays sensor data if they have matching advertisement data .

```
 /cygdrive/c/Program\ Files/IronPython\ 2.7/ipy.exe C:/Us...
Found device:
Time: 2019-03-06 14:21:47.034000
Name: SoLaRSL10_V2_E
UUID: 00000000-0000-0000-0000-60c0bf0d62d2
Advertisement data:
  Flags: 0x04
  LongLocalName: SoLaRSL10_V2_E
  ManufacturerSpecificData: 0x620345087B07920185A4
  Company Identifier: ON Semiconductor
  Environmental sensor data frame: 0x45L
    Temperature: 29.39 degC
    Humidity: 19.38 %
    Pressure: 99748 Pa
Found device:
Time: 2019-03-06 14:21:57.052000
Name: SoLaRSL10_V2_E
UUID: 00000000-0000-0000-0000-60c0bf0d62d2
Advertisement data:
  Flags: 0x04
  LongLocalName: SoLaRSL10_V2_E
  ManufacturerSpecificData: 0x620345087B07920185A4
  Company Identifier: ON Semiconductor
  Environmental sensor data frame: 0x45L
    Temperature: 29.39 degC
    Humidity: 19.38 %
    Pressure: 99748 Pa
```

Figure 18. Displayed Sensor Data as Captured by the RSL10 USB Dongle

SUMMARY

With this reference platform, **onsemi** has demonstrated it is entirely possible to make a low cost, small form-factor sensor node powered entirely by solar energy and with features including continuous sensor monitoring and data transmission to the cloud gateway. Several use cases will take huge benefit of the new technology and capabilities of the RSL10 Solar Cell Multi-Sensor platform, including Smart Buildings, City Management, and Mobile Health. By using this platform to create new innovative sensor designs, developers can help revolutionize IoT by closing the gap in the energy needs created by implementing billions of smart sensors.

Bluetooth is a registered trademark of Bluetooth SIG.

ZigBee is a registered trademark of ZigBee Alliance.

Android is a trademark of Google LLC.

IOS is a trademark or registered trademark of Cisco in the U.S. and other countries and is used under license.

onsemi, **Onsemi**, and other names, marks, and brands are registered and/or common law trademarks of Semiconductor Components Industries, LLC dba "**onsemi**" or its affiliates and/or subsidiaries in the United States and/or other countries. **onsemi** owns the rights to a number of patents, trademarks, copyrights, trade secrets, and other intellectual property. A listing of **onsemi**'s product/patent coverage may be accessed at www.onsemi.com/site/pdf/Patent-Marking.pdf. **onsemi** reserves the right to make changes at any time to any products or information herein, without notice. The information herein is provided "as-is" and **onsemi** makes no warranty, representation or guarantee regarding the accuracy of the information, product features, availability, functionality, or suitability of its products for any particular purpose, nor does **onsemi** assume any liability arising out of the application or use of any product or circuit, and specifically disclaims any and all liability, including without limitation special, consequential or incidental damages. Buyer is responsible for its products and applications using **onsemi** products, including compliance with all laws, regulations and safety requirements or standards, regardless of any support or applications information provided by **onsemi**. "Typical" parameters which may be provided in **onsemi** data sheets and/or specifications can and do vary in different applications and actual performance may vary over time. All operating parameters, including "Typicals" must be validated for each customer application by customer's technical experts. **onsemi** does not convey any license under any of its intellectual property rights nor the rights of others. **onsemi** products are not designed, intended, or authorized for use as a critical component in life support systems or any FDA Class 3 medical devices or medical devices with a same or similar classification in a foreign jurisdiction or any devices intended for implantation in the human body. Should Buyer purchase or use **onsemi** products for any such unintended or unauthorized application, Buyer shall indemnify and hold **onsemi** and its officers, employees, subsidiaries, affiliates, and distributors harmless against all claims, costs, damages, and expenses, and reasonable attorney fees arising out of, directly or indirectly, any claim of personal injury or death associated with such unintended or unauthorized use, even if such claim alleges that **onsemi** was negligent regarding the design or manufacture of the part. **onsemi** is an Equal Opportunity/Affirmative Action Employer. This literature is subject to all applicable copyright laws and is not for resale in any manner.

PUBLICATION ORDERING INFORMATION

LITERATURE FULFILLMENT:

Email Requests to: orderlit@onsemi.com

onsemi Website: www.onsemi.com

TECHNICAL SUPPORT

North American Technical Support:

Voice Mail: 1 800-282-9855 Toll Free USA/Canada

Phone: 011 421 33 790 2910

Europe, Middle East and Africa Technical Support:

Phone: 00421 33 790 2910

For additional information, please contact your local Sales Representative